

- > Port size: DN 8 ... 50, 1/4" ... 2" (ISO G/NPT)
- > High flow rate
- > For robust industry solutions
- > Damped operation
- > Suitable for vacuum
- > For systems with low or fluctuating pressure
- > Valve operates without differential pressure
- > Solenoid interchangeable without tools (*Click-on*) only solenoid 915x and 940x



Technical features

Medium:
Neutral gases and liquids

Switching function:
Normally closed

Operation:
Solenoid actuated, with forced lifting

Mounting position:
Optional, preferably solenoid vertical on top

Flow direction:
Determined

Port size:
G1/4, G3/8, G1/2, G3/4, G1, G1 1/4, G1 1/2, G2 1/4 NPT, 3/8 NPT, 1/2 NPT, 3/4 NPT, 1 NPT, 1 1/4 NPT, 1 1/2 NPT, 2 NPT

Operating pressure:
See table

Fluid temperature:
-10° ... +90°C (+14° ... +194°F)

Ambient temperature:
-10° ... +50°C (+14° ... +122°F)

Material:
Body: Brass (CW617N)
Seat seal: NBR-K
Internal parts: Stainless steel, PVDF, Brass

For contaminated fluids insertion of a strainer is recommended.

Technical data - standard models

Symbol	Port size	Orifice (mm)	Flow kv value *1) (m³/h)	Operating pressure *2) (bar)	Weight (kg)	Model Solenoid in V d.c.	Model Solenoid in V a.c.
	G1/4	8	1,9	0 ... 10	0,8	8254000.9151.xxxxx	8254000.9154.xxxxx
	G1/4	8	1,9	0 ... 16.3*)	0,8	8254000.9301.xxxxx	8254000.9304.xxxxx
	1/4 NPT	8	1,9	0 ... 10	0,8	8264000.9151.xxxxx	8264000.9154.xxxxx
	1/4 NPT	8	1,9	0 ... 16.3*)	0,8	8264000.9301.xxxxx	8264000.9304.xxxxx
	G3/8	10	3	0 ... 10	0,8	8254100.9151.xxxxx	8254100.9154.xxxxx
	G3/8	10	3	0 ... 16.3*)	0,8	8254100.9301.xxxxx	8254100.9304.xxxxx
	3/8 NPT	10	3	0 ... 10	0,8	8264100.9151.xxxxx	8264100.9154.xxxxx
	3/8 NPT	10	3	0 ... 16.3*)	0,8	8264100.9301.xxxxx	8264100.9304.xxxxx
	G1/2	12	3,4	0 ... 10	0,9	8254200.9151.xxxxx	8254200.9154.xxxxx
	G1/2	12	3,4	0 ... 16.3*)	0,9	8254200.9301.xxxxx	8254200.9304.xxxxx
	1/2 NPT	12	3,4	0 ... 10	0,9	8264200.9151.xxxxx	8264200.9154.xxxxx
	1/2 NPT	12	3,4	0 ... 16.3*)	0,9	8264200.9301.xxxxx	8264200.9304.xxxxx
	G3/4	20	5,8	0 ... 10	1	8254300.9151.xxxxx	8254300.9154.xxxxx
	G3/4	20	5,8	0 ... 16.3*)	1	8254300.9301.xxxxx	8254300.9304.xxxxx
	3/4 NPT	20	5,8	0 ... 10	1	8264300.9151.xxxxx	8264300.9154.xxxxx
	3/4 NPT	20	5,8	0 ... 16.3*)	1	8264300.9301.xxxxx	8264300.9304.xxxxx
	G1	25	8	0 ... 10	1,3	8254400.9151.xxxxx	8254400.9154.xxxxx
	G1	25	8	0 ... 16.3*)	1,3	8254400.9301.xxxxx	8254400.9304.xxxxx
	1 NPT	25	8	0 ... 10	1,3	8264400.9151.xxxxx	8264400.9154.xxxxx
	1 NPT	25	8	0 ... 16.3*)	1,3	8264400.9301.xxxxx	8264400.9304.xxxxx
	G 1 1/4	32	23	0 ... 16	4,3	8254500.9401.xxxxx	8254500.9404.xxxxx
	1 1/4 NPT	32	23	0 ... 16	4,3	8264500.9401.xxxxx	8264500.9404.xxxxx
	G 1 1/2	40	25	0 ... 16	4,3	8254600.9401.xxxxx	8254600.9404.xxxxx
	1 1/2 NPT	40	25	0 ... 16	4,3	8264600.9401.xxxxx	8264600.9404.xxxxx
G2	50	41	0 ... 16	5,4	8254700.9401.xxxxx	8254700.9404.xxxxx	
2 NPT	50	41	0 ... 16	5,4	8264700.9401.xxxxx	8264700.9404.xxxxx	

xxxxx Please insert voltage and frequency codes

*1) Cv-value (US) ≈ kv value x 1,2

*2) For gases and liquid fluids up to 25 mm²/s (cSt)

*3) For liquid mediums and an operating pressure > 10 bar is the maximum allowed differential pressure limited to 2 bar.

Option selector

82★4★ ★★.★ ★★.★ ★★ ★★

Thread form	Substitute
ISO G	5
NPT	6
Port size	Substitute
1/4"	0
3/8"	1
1/2"	2
3/4"	3
1"	4
1 1/4"	5
1 1/2"	6
2"	7
Valve options	Substitute
Normally open (NO), up to G1 (1 NPT) with solenoid 9150 max. 10 bar, with solenoid 9300 max. 16 bar, from G1 1/4 (1 1/4 NPT) only with solenoid 8400 max. 16 bar	01
Manual override, from G1 1/4 (1 1/4 NPT) up to G2 (2 NPT)	02
Seat seal FPM, Fluid temperature -5 ... +110°C	03
Seat seal EPDM, for hot water, Fluid temperature -10 ... +110°C	14
Normally open, Seat seal FPM, Fluid temperature -5 ... +110°C, from G1 1/4 (1 1/4 NPT) only with solenoid 8400 max. 16 bar	17
Version for drinking water with test according to KTW	88

Frequency	Substitute
See table frequency codes	xx
Voltage	Substitute
See Voltage codes	xxx
Solenoid options	Substitute
G1/4 ... 1 Operating pressure 0 ... 10 bar Solenoid in V d.c.	9151
G1/4 ... 1 Operating pressure 0 ... 10 bar Solenoid in V a.c.	9154
G1/4 ... 1 Operating pressure 0 ... 16 bar *2) Solenoid in V d.c.	9301
G1/4 ... 1 Operating pressure 0 ... 16 bar *2) Solenoid in V a.c.	9304
G1 1/4 ... 2 Operating pressure 0 ... 16 bar Solenoid in V d.c.	9401
G1 1/4 ... 2 Operating pressure 0 ... 16 bar Solenoid in V a.c.	9404

*2) For liquid mediums and an operating pressure > 10 bar is the maximum allowed differential pressure limited to 2 bar

Standard solenoid systems

Voltage and Frequency Solenoid 9151/9154 *1)					
Code Voltage	Code Frequency	Voltage	Frequency	Power consumption	
				Inrush	Holding
024	00	24 V DC	-	18 W	18 W
024	50	24 V AC	50 Hz	20 VA	20 VA
110	50	110 V AC	50 Hz	20 VA	20 VA
120	60	120 V AC	60 Hz	20 VA	20 VA
230	50	230 V AC	50 Hz	20 VA	20 VA
Voltage and Frequency Solenoid 9301/9304 *1)					
024	00	24 V DC	-	18 W	18 W
024	50	24 V AC	50 Hz	20 VA	20 VA
110	50	110 V AC	50 Hz	20 VA	20 VA
120	60	120 V AC	60 Hz	20 VA	20 VA
230	50	230 V AC	50 Hz	20 VA	20 VA
Voltage and Frequency Solenoid 9401/9404 *1)					
024	00	24 V DC	-	38 W	38 W
024	49	24 V AC	40 ... 60 Hz	42 VA	42 VA
110	49	110 V AC	40 ... 60 Hz	42 VA	42 VA
120	49	120 V AC	40 ... 60 Hz	42 VA	42 VA
230	49	230 V AC	40 ... 60 Hz	42 VA	42 VA

*1)  coil only (with the exception of solenoid 94xx up to 41 V a.c.)

Further versions on request!

Electrical details for all solenoid systems

Design	DIN VDE 0580
Voltage range	±10%
Duty cycle	100% ED
Protection class	EN 60529 IP65
Socket	Form A acc. to DIN EN 175301-803 (included)

According to DIN VDE 0580 at a solenoid temperature of +20°C.
At operating state temperature the input power of a coil decreases by up to ca. 30% due to physical reasons.



Additional solenoid systems

ATEX category	Protection class	Solenoid	Standard voltages
I/2GD	EEx me II T3 T 140°C	9356	24 V d.c., 110 V a.c., 230 V a.c.
I/3G	Ex nA IIB T4 Gc	9326	24 V d.c., 110 V a.c., 230 V a.c.
I/3D	Ex II 3D Ex tc IIB T130°C Dc IP65		
I/3G	Ex nA IIB T4 Gc	8426	24 V d.c., 110 V a.c., 230 V a.c.
I/3D	Ex II 3D Ex tc IIB T130°C Dc IP65		
I/2G	EEx me II T3 T 140°C	8441	24 V d.c., 110 V a.c., 230 V a.c.
I/3G	Ex nA IIB T4 Gc	9176	24 V d.c., 110 V a.c., 230 V a.c.
I/3D	Ex II 3D Ex tc IIB T130°C Dc IP65		
I/2GD	EEx me II T3 T 140°C	9191	24 V d.c., 110 V a.c., 230 V a.c.
I/3G	Ex nA IIB T4 Gc	9426	24 V d.c., 110 V a.c., 230 V a.c.
I/3D	Ex II 3D Ex tc IIB T130°C Dc IP65		

Attention!

The conditions imposed on the Ex approvals lead to reduction of the permissible standard temperature ranges in the cases of explosion protected solenoids.

Section View and Dimensions

G1/4 ... 1 with solenoid 915x (10 bar)
1/4 ... 1 NPT with solenoid 915x (10 bar)

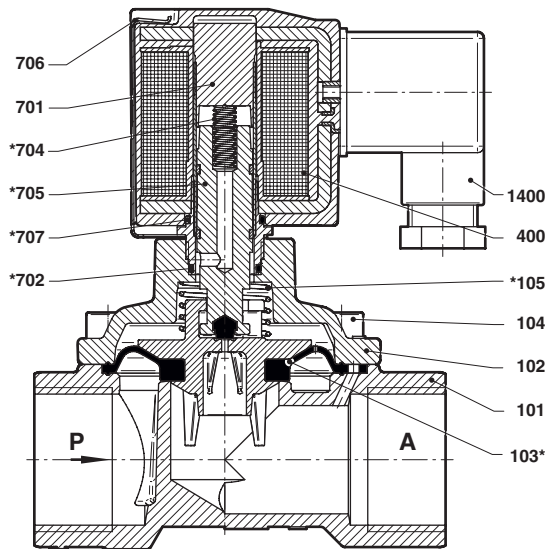

No.	Description
101	Valve body
102	Valve cover
*103	Diaphragm
104	Allen head screw
*105	Pressure spring
400	Solenoid
701	Core tube
*702	O-ring
*704	Pressure spring
*705	Core
706	Spring clip
*707	O-ring
1400	Socket (included)

* These individual parts form a complete wearing unit.
When ordering spare parts please state Model No. and Series No.

Dimensions in mm
Projection/First angle

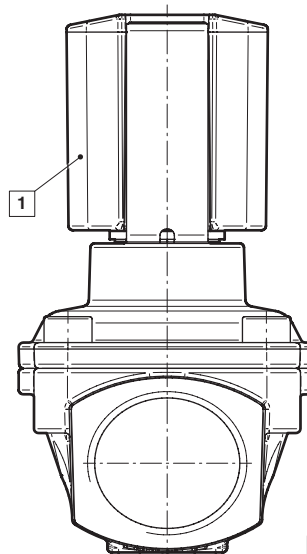
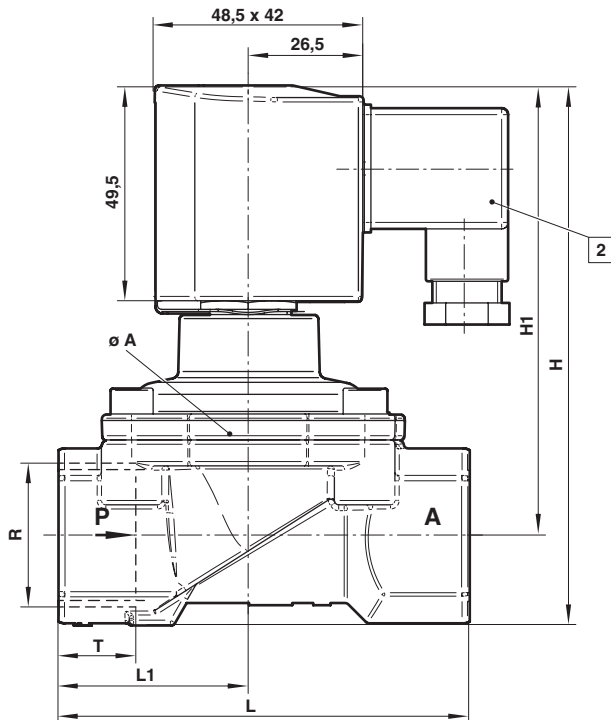

- 1 Solenoid rotatable 360°
- 2 Socket turnable 4 x 90°
(Socket included)

Port size R	ø A *1)	H	H1	L	L1	T	Model
G1/4	44	104	92,5	60	27,5	12	8254000.915x.xxxxx
1/4 NPT	44	104	92,5	60	27,5	10	8264000.915x.xxxxx
G3/8	44	104	92,5	60	27,5	12	8254100.915x.xxxxx
3/8 NPT	44	104	92,5	60	27,5	10,5	8264100.915x.xxxxx
G1/2	44	108	94,5	67	31	14	8254200.915x.xxxxx
1/2 NPT	44	108	94,5	67	31	13,5	8264200.915x.xxxxx
G3/4	50	115	99	80	36,5	16	8254300.915x.xxxxx
3/4 NPT	50	115	99	80	36,5	14	8264300.915x.xxxxx
G1	62	124	103,5	95	44	18	8254400.915x.xxxxx
1 NPT	62	124	103,5	95	44	17	8264400.915x.xxxxx

*1) ø A = max. depth

Section View and Dimensions

G1/4 ... 1 with solenoid 930x (16 bar)
1/4 ... 1 NPT with solenoid 930x (16 bar)

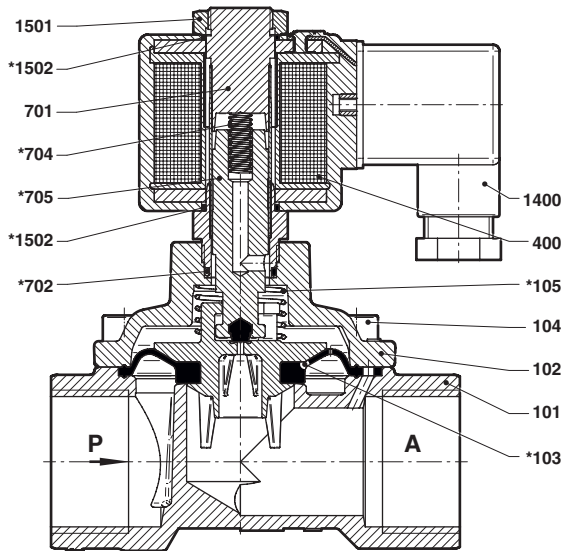

No.	Description
101	Valve body
102	Valve cover
*103	Diaphragm
104	Allen head screw
*105	Pressure spring
400	Solenoid
701	Core tube
*702	O-ring
*704	Pressure spring
*705	Core
1400	Socket (included)
1501	Special hexagon nut
*1502	O-ring (2x)

* These individual parts form a complete wearing unit.
When ordering spare parts please state Model No. and Series No.

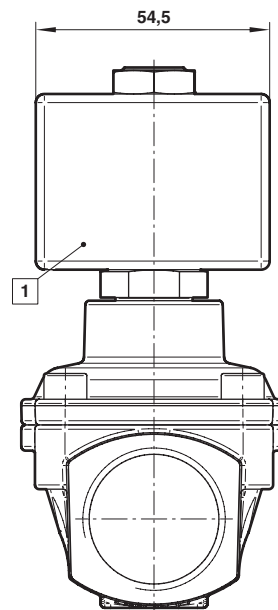
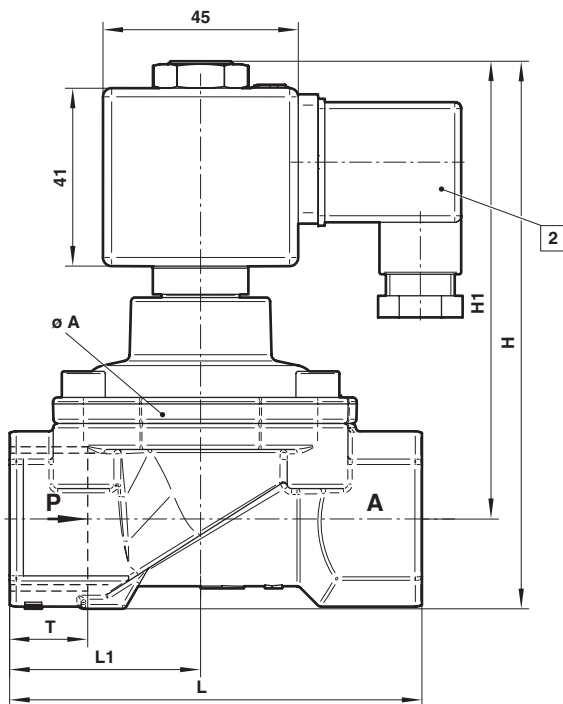

Dimensions in mm
Projection/First angle



- 1 Solenoid rotatable 360°
- 2 Socket turnable 4 x 90°
(Socket included)

Port size R	ø A *1)	H	H1	L	L1	T	Model
G1/4	44	104	92,5	60	27,5	12	8254000.930x.xxxxx
1/4 NPT	44	104	92,5	60	27,5	10	8264000.930x.xxxxx
G3/8	44	104	92,5	60	27,5	12	8254100.930x.xxxxx
3/8 NPT	44	104	92,5	60	27,5	10,5	8264100.930x.xxxxx
G1/2	44	108	94,5	67	31	14	8254200.930x.xxxxx
1/2 NPT	44	108	94,5	67	31	13,5	8264200.930x.xxxxx
G3/4	50	115	99	80	36,5	16	8254300.930x.xxxxx
3/4 NPT	50	115	99	80	36,5	14	8264300.930x.xxxxx
G1	62	124	103,5	95	44	18	8254400.930x.xxxxx
1 NPT	62	124	103,5	95	44	17	8264400.930x.xxxxx

*1) ø A = max. depth

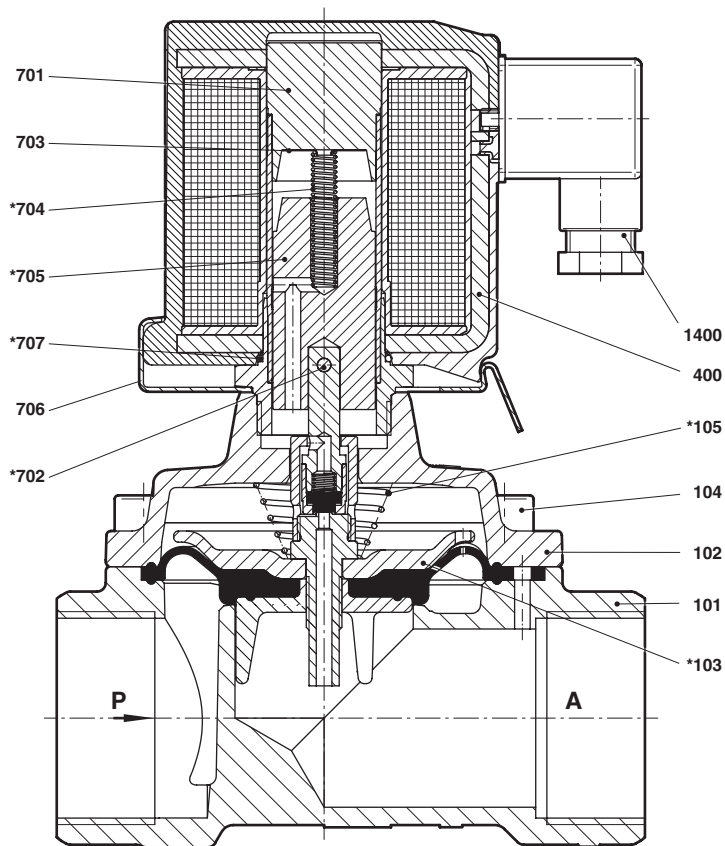
Section View
G1 1/4 ... 1 with solenoid 940x (16 bar)
1 1/4 ... 1 NPT with solenoid 940x (16 bar)

No.	Description
101	Valve body
102	Valve cover
*103	Diaphragm
104	Allen head screw
*105	Pressure spring
400	Solenoid
701	Core tube
*702	O-ring
703	Round plate
*704	Pressure spring
*705	Core
706	Spring clip
*707	O-ring
1400	Socket (included)

* These individual parts form a complete wearing unit.

When ordering spare parts please state Model No. and Series No.

Dimensions

G1 1/4 ... 1 with solenoid 940x (16 bar)
1 1/4 ... 1 NPT with solenoid 940x (16 bar)

Abmessungen in mm
Projection/First angle

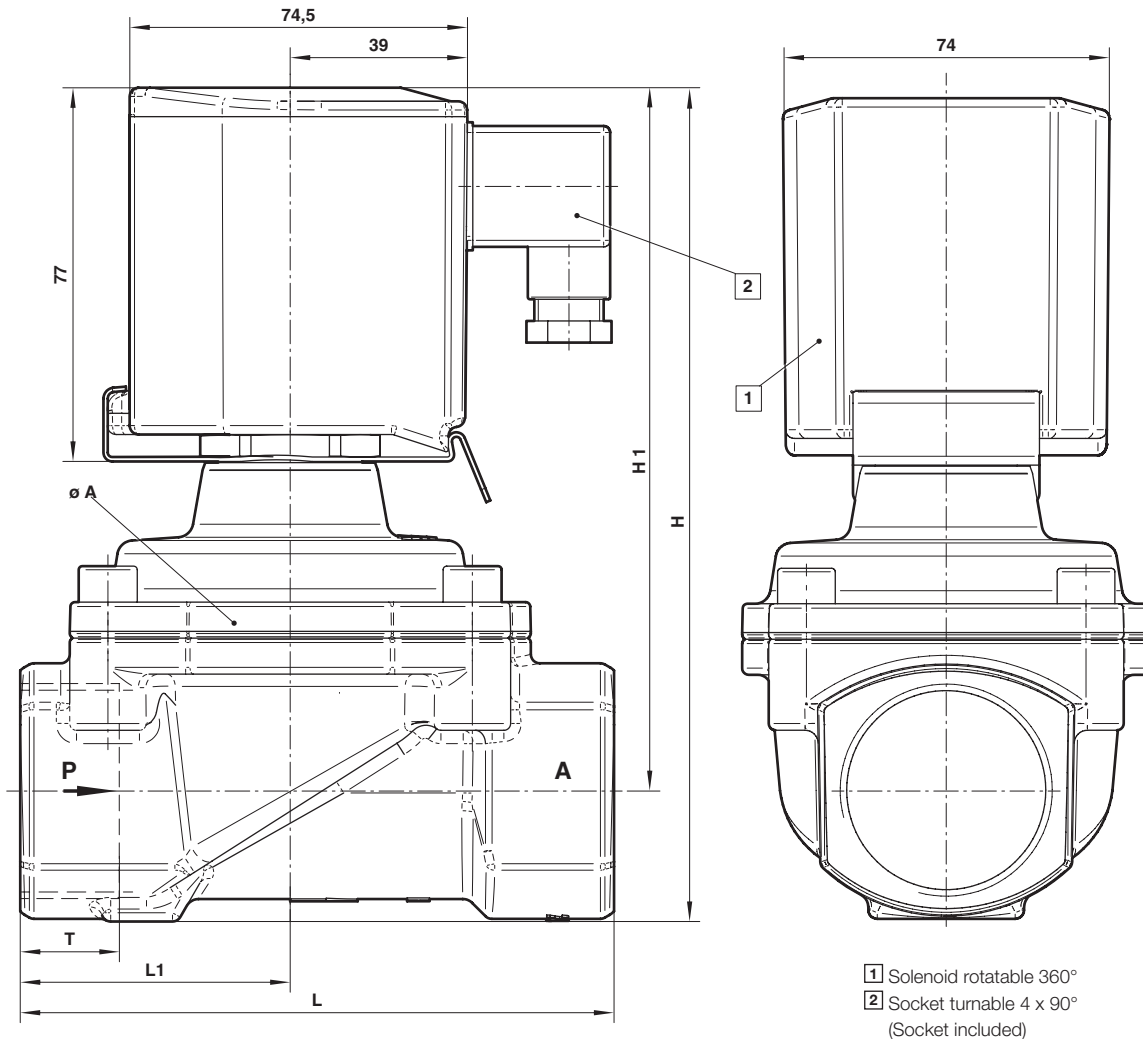

Port size R	ø A *1)	H	H1	L	L1	T	Model
G1 1/4	92	186	157	132	60	20	8254500.940x.xxxxx
1 1/4 NPT	92	186	157	132	60	17	8264500.940x.xxxxx
G1 1/2	92	186	157	132	60	22	8254600.940x.xxxxx
1 1/2 NPT	92	186	157	132	60	17	8264600.940x.xxxxx
G2	109	201,5	167	160	74	24	8254700.940x.xxxxx
2 NPT	109	201,5	167	160	74	17,5	8264700.940x.xxxxx

*1) ø A = max. depth

Note to Pressure Equipment Directive (PED):

The valves of this series, including the connection size DN 25 (G 1), are according to Art. 3 § 3 of the Pressure Equipment Directive (PED) 97/23/EG. This means interpretation and production are in accordance to engineers practice wellknown in the member countries. The CE-sign at the valve refers not to the PED. Thus the declaration of conformity is not longer applicable for this directive.

For valves > DN 25 (G 1) Art. 3 § (1) No.1.4 applies:

The basic requirements of the Enclosure I of the PED must be fulfilled. The CE-sign at the valve includes the PED. A certificate of conformity of this

directive will be available on request.

Note to Electromagnetic Compatibility Guideline (EEC):

The valves shall be provided with an electrical circuit which ensures the limits of the harmonised standards EN 61000-6-3 and EN 61000-6-1 are observed, and hence the requirements of the Electromagnetic Compatibility Guideline (2004/108/EG) satisfied.